



DYNOPTIC

DSL-340 MkIII

Double Pass Dust Monitor

Measures 0-1000mg/m³ using DDP

Ideal for monitoring dust levels in the exhaust gas of industrial combustion or air filtration processes.



- Innovative Dynamic Detection Principle (DDP) measurement technique
- Immune to gradual reductions in absolute intensity of the light signal so less susceptible to drift
- Measurement reading as mg/m³ (when calibrated against standard reference measurements)
- Internal electronic calibration check facility
- Rugged 316 stainless steel construction
- Choice of interface options enabling easy integration
- Free utility software for PC based setup, control, and data logging
- Optional Operator Interface with different mounting configurations

The DSL-340 is an optical instrument designed to measure the concentration of dust or particulate matter suspended in the exhaust gas passing through a duct, stack, or flue; typically the exhaust gas from an industrial combustion process or air filtration system.

The DSL-340 uses the innovative Dynamic Detection Principle (DDP) which measures fluctuations in the intensity of a light beam, using a folded beam Transceiver /Reflector arrangement. Increased particulate density in the stack causes the amplitude of these fluctuations to increase. When calibrated against standard reference measurements, the amplitude of this signal relates directly to the particulate concentration in the stack, and this can be used to present as a reading in mg/m³.

Unlike the standard transmission technique, DDP has immunity to gradual reductions in the absolute intensity of the light signal and therefore, has the advantage that it is significantly less susceptible to drift with time, temperature or dirtying optics, than traditional opacity monitors using the standard transmission technique.

The light source in the Transceiver is a long life, stabilised green LED which offers long life and stable intensity. The transmitted light beam is pulsed to give complete immunity to ambient light levels. The intensity of the transmitted light is monitored at source so that any variations in the emitted light level are compensated in the received signal. The Transceiver has on board temperature measuring to provide stability over temperature.

The DSL-340 is available with or without an Operator Interface (control unit) so for the most cost effective monitoring solution the DSL-340 can operate as a "stand-alone" head pair consisting of the Transceiver head (TRX) and Reflector head (RF), with all electrical connections (including outputs such as the alarm relays, 4-20mA, and ModBus) being made inside the TRX head. As a stand-alone instrument the DSL-340 is set-up and controlled using the supplied utility software, installed on a PC or laptop, and connected via the USB connector on the TRX. When supplied with an Operator Interface (OI) all power supply and output connections are made in the OI rather than the TRX. The OI has a bright 4 digit LED display and a simple 4 button keypad which allow full command and control of the instrument.

The DSL-340 has no moving parts, is of rugged design and has an excellent reliability record. Regular maintenance simply involves cleaning the TRX and RF lenses, which are easily accessible due to our latched head design. Both the TRX and RF are supplied with an air purge body which, when connected to a high volume source of clean air (a blower is recommended), will resist particle deposition on the lenses and further lengthen service intervals.



DynOptic Systems Ltd, Furlong House, Crowfield, Brackley, Northamptonshire NN13 5TW United Kingdom
Telephone: +44 (0)1280 850521, Facsimile: +44 (0)1280 850568
Email: contact@dynoptic.com, Website: www.dynoptic.com



© DynOptic Systems Ltd
11/10/2013 V1.2

All technical details and specifications are subject to change without notice



DYNOPTIC

DSL-340 MkIII

Double Pass Dust Monitor

Measures 0-1000mg/m³ using DDP

Specification:

Measurement Performance

No.	Parameter	Units	Min	Max	Comment
1	Path Length (flange to flange)	m	0.5	10	Flange-to-flange separation
2	Measuring Range	mg/m ³	0.0	1000.0	User selectable
3	Accuracy	%	-2	+2	Relative to the maximum range
4	Resolution	mg/m ³		0.1	Display resolution
5	Damping	s	1	60	Selectable
6	Drift with Temperature	%	-0.5	+0.5	Over operating range
7	Operating Wavelength	nm	510	540	Green LED

Power & Air Requirements

8	Voltage	Vdc	+24		Optional 90-260Vac PSU available
9	Voltage Tolerance	%	-10	+10	
10	Nominal Current Consumption	mA		500	
11	Power Up Current Consumption	mA		500	
12	Air Supply Volume Flow	L/min	50	200	To each air-purge body.
13	Air Supply Fitting				1" BSP threaded aperture in each air-purge body

Cable and Wire

14	Cable type – OI/TRX Interconnection	cores	4		Screened multi-core, such as Belden 9873
15	Wire Size at Terminal Connections	AWG	20	14	

Interface Options

16	Serial Comms				ModBus RTU via RS485 (OI or TRX) Internal USB (OI), external USB (TRX)
17	Analogue Output (one)	mA	4	20	Isolated and scalable
18	Digital Relay Contacts (two)	A	0	3	@30Vdc (signal level and data valid)

Physical

19	Ingress Protection: - Heads		IP65		For external use
20	Ingress Protection: - OI Wall Mounted - OI Panel Mounted - OI Rack Mounted		IP65 IP64 IP50		Hinged door and terminal compartment shut. From front face of panel when installed. Indoor use only
21	Ambient Operating Temperature	°C	-20	+55	Air temperature around the heads.
22	Operating Humidity	%		100	Air humidity around the heads.
23	Gas Temperature	°C		+600	Heat insulating gaskets included. (Higher temperatures on request)
24	Regulatory Compliance				2004/108/EC (Electromagnetic Radiation) 2006/95/EC (Low Voltage)
25	Materials: - Heads	316 Stainless Steel (powder coated)			
26	Materials: - Air-Purge Bodies	Powder coated cast aluminium. (optional stainless steel version available)			
27	Materials: - OI Wall Mounted	UL rated polycarbonate enclosure; aluminium front panel with PU laminate overlay and with nylon cable glands			
	- OI Panel Mounted	Powder coated steel back-box; aluminium front panel with PU laminate overlay and with nylon cable glands			
	- OI Rack Mounted	Powder coated steel back-box; aluminium front panel with PU laminate overlay and with nylon cable glands.			
28	Weight	kg		2.5	TX or Reflector head plus Air-Purge body
39	Weight: - OI Wall Mounted	kg		1.3	
	- OI Panel Mounted			1.3	
30	Warranty	months	24		Return to base warranty. Extensions available



DynOptic Systems Ltd, Furlong House, Crowfield, Brackley, Northamptonshire NN13 5TW United Kingdom
Telephone: +44 (0)1280 850521, Facsimile: +44 (0)1280 850568
Email: contact@dynoptic.com, Website: www.dynoptic.com



© DynOptic Systems Ltd
11/10/2013 V1.2

All technical details and specifications are subject to change without notice



DYNOPTIC

DSL-340 MkIII

Double Pass Dust Monitor
Measures 0-1000mg/m³ using DDP

Configuration Options:

Configured with an
OI: Wall, Panel, or
Rack Mounting

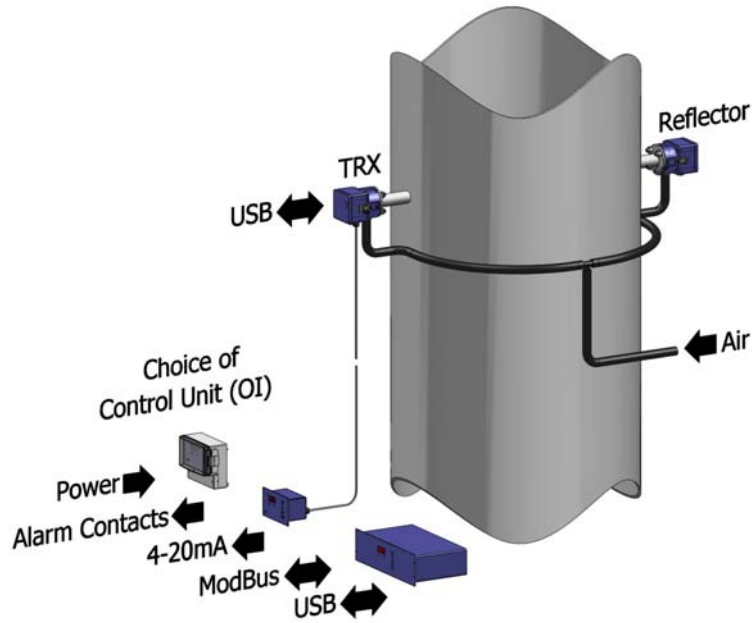

OR

Stand Alone
Configuration

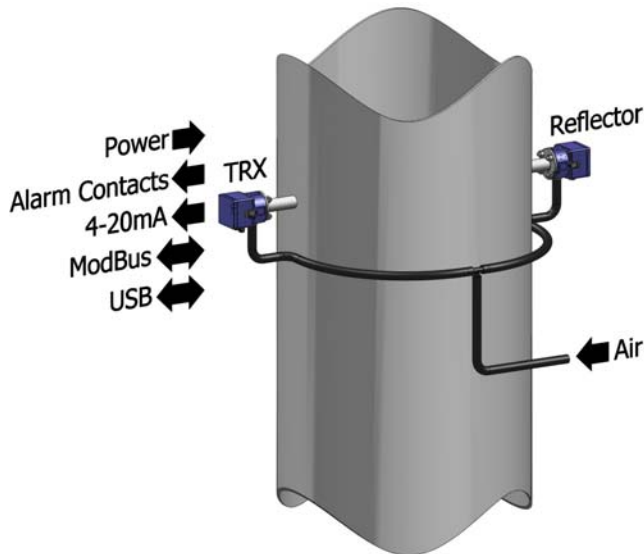

DynOptic Systems Ltd, Furlong House, Crowfield, Brackley, Northamptonshire NN13 5TW United Kingdom
Telephone: +44 (0)1280 850521, Facsimile: +44 (0)1280 850568
Email: contact@dynoptic.com, Website: www.dynoptic.com



© DynOptic Systems Ltd
11/10/2013 V1.2

All technical details and specifications are subject to change without notice



DYNOPTIC

DSL-340 MkIII

Double Pass Dust Monitor
Measures 0-1000mg/m³ using DDP

Dimensions (mm):

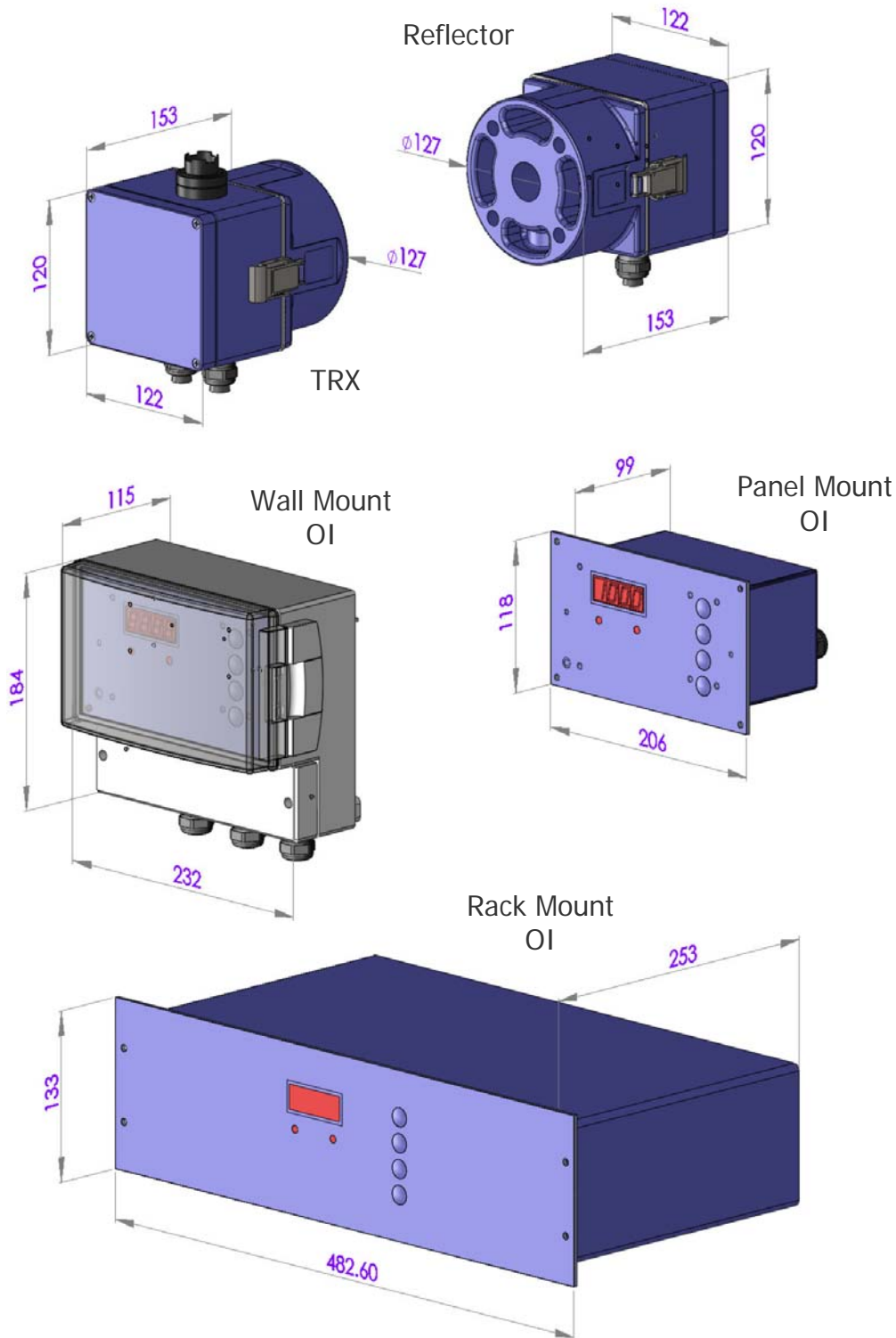

DynOptic Systems Ltd, Furlong House, Crowfield, Brackley, Northamptonshire NN13 5TW United Kingdom
Telephone: +44 (0)1280 850521, Facsimile: +44 (0)1280 850568
Email: contact@dynoptic.com, Website: www.dynoptic.com



© DynOptic Systems Ltd
11/10/2013 V1.2

All technical details and specifications are subject to change without notice



DYNOPTIC

DSL-340 MkIII

Double Pass Dust Monitor
Measures 0-1000mg/m³ using DDP

Ordering Details:

DSL-340 MkIII X X X X

A = Aluminium air-purge body
S = Stainless steel air-purge body

D = 24 Vdc powered
A = 90-260 Vac powered

N = No OI
W = Wall mounted OI
P = Panel mounted OI
R = Rack mounted OI

S = Short path length version
(0.5 - 4m flange to flange separation)

L = Long path length version
(2 - 10m flange to flange separation)



DynOptic Systems Ltd, Furlong House, Crowfield, Brackley, Northamptonshire NN13 5TW United Kingdom
Telephone: +44 (0)1280 850521, Facsimile: +44 (0)1280 850568
Email: contact@dynoptic.com, Website: www.dynoptic.com



© DynOptic Systems Ltd
11/10/2013 V1.2

All technical details and specifications are subject to change without notice







DYNOPTIC

DSL-340 MkIII

Double Pass Dust Monitor

Measures 0-1000mg/m³ using DDP

Options & Accessories:

Description	Order Code	Notes
Mounting Flange & Fixing Kit 	ASY-067	1.5" ANSI 150 flange pattern with 240mm long extension tube (x2).
	ASY-071	Contains M14 x 100mm studding, flat washers, spring washers and M14 nuts.
Weather Cover 	ASY-080	Hinged stainless steel weather / heat cover for protecting externally mounted heads.
Laser Alignment Tool 	DSL-LAT08	Tool to aid the alignment of the two heads across the stack.
Blower Kit 	BK-40B-110	Blower kit for purge air. 110 Vac; single phase
	BK-40B-240	Blower kit for purge air. 240 Vac; single phase
	BK-40B-415	Blower kit for purge air. 415 Vac; three phase
Compressed Air Kit 	ASY-181	For use with compressed air purge. Includes pressure regulator, in-line filters, and compressed air adaptors for the purge body.
Interconnecting Cable	CBL-078	Cable for RX to TX and RX to OI. 6-core, screened pair, 20AWG. Belden equivalent 9873. Max length 300m.



DynOptic Systems Ltd, Furlong House, Crowfield, Brackley, Northamptonshire NN13 5TW United Kingdom
 Telephone: +44 (0)1280 850521, Facsimile: +44 (0)1280 850568
 Email: contact@dynoptic.com, Website: www.dynoptic.com



© DynOptic Systems Ltd
 11/10/2013 V1.2

All technical details and specifications are subject to change without notice



DYNOPTIC

DSL-340 MkIII

Double Pass Dust Monitor

Measures 0-1000mg/m³ using DDP

Boxed PSU		PSU-007	Multi AC input, 24Vdc output 25W, IP67 rated enclosure
-----------	---	---------	---

Note that the actual part may differ from the above representative pictures.



DynOptic Systems Ltd, Furlong House, Crowfield, Brackley, Northamptonshire NN13 5TW United Kingdom

Telephone: +44 (0)1280 850521, Facsimile: +44 (0)1280 850568

Email: contact@dynoptic.com, Website: www.dynoptic.com



© DynOptic Systems Ltd
11/10/2013 V1.2

All technical details and specifications are subject to change without notice